



**ASBESTOS  
FREE**



**LUXER BOARD**

*FOR THE BUILDINGS OF TOMORROW*



**SCAN HERE**

# PRODUCT CATALOGUE





# ABOUT US

**Luxer Board** is a building material product in the form of non-asbestos cement board made from a mixture of cement, cellulose fiber, and other additives, resulting in a strong and durable product.

In addition to being strong, Luxer board is also fire and water-resistant, termite and mold-proof, and most importantly, asbestos-free, making it safe for the health of its users.

Produced by **PT Bangunperkasa Adhitamasentra**, one of the largest cement board manufacturers that has dominated the cement board market in Indonesia, and has also exported to several countries including South Korea, Myanmar, Vietnam, Dubai, The Philippines, and Australia.

Supported by three large factories located in several cities on the island of Java to produce cement boards to meet local and export cement board demands. Luxer board continues to innovate to present new products tailored to consumer demand, including products for decks and floors and decorative products that follow contemporary trends.



*Luxer Board specifications include:*



*ISO 9001:2015 quality management system for non-asbestos cement board production.*



*ISO 140 soundproofing standard for building elements.*



*Fire resistance according to SNI 1741-2008 results equivalent to JIS 1304.*

*Incombustibility based on AS 1530.1-1992*



*Gold green label certificate from the Green Product Council Indonesia.*



*CE Mark Certificate.*



*Australian standard AS/NZS 2908.2.2000 Lic: SMK41466 SAI GLOBAL*



**ASBESTOS FREE**



**STRONG & DURABLE**



**MOISTURE RESISTANT**



**EASY APPLICATION**



**FIRE RESISTANT**



**FUNGI RESISTANT**



**SOUND INSULATION**



**TERMITES RESISTANT**



**SMOOTH SURFACE**



**LUXER BOARD**

FOR THE BUILDINGS OF TOMORROW

**Luxer Board**  
Smooth



## BOARD

*Luxer Board* products can be applied for ceilings, partitions, or roof bases.

Suitable for use in office buildings, factories, apartments, or residential houses.

Thickness (mm)	3.5	4	4.5	6	9	12
Length (mm)	2440	2440	2440	2440	2440	2440
Width (mm)	1220	1220	1220	1220	1220	1220
Weight (kg)	17	19	21.5	29	45.5	61.3
Application	Ceiling		Partition/Wall		Façade/Cladding	



## Cladding

*Luxer Cladding* is intended for use in outdoor areas as walls with thickness capable of withstanding sunlight and rain or all seasons.

**Luxer Cladding**

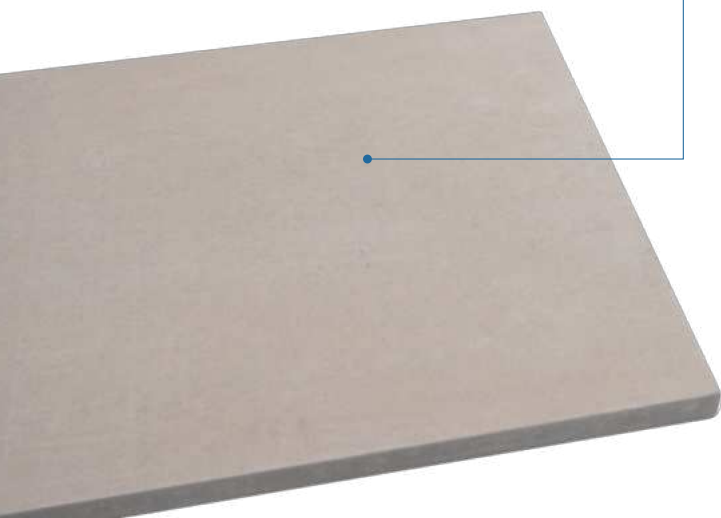

**Luxer Cladding**



## CLADDING APPLICATION

### FRAMES

Vertical frame that could be applied such as:

1. Furring channel 75 x 45 x 1.6 mm.
2. Hollow 60 x 40 x 1.6 mm (min).
3. L plat 50 x 50 x 5 mm (min)

Horizontal frame could apply metal frameworks CNP 75, 100 and 125.

- The maximum distance vertical frameworks is 610 mm.
- The maximum distance horizontal frameworks is 1220 mm

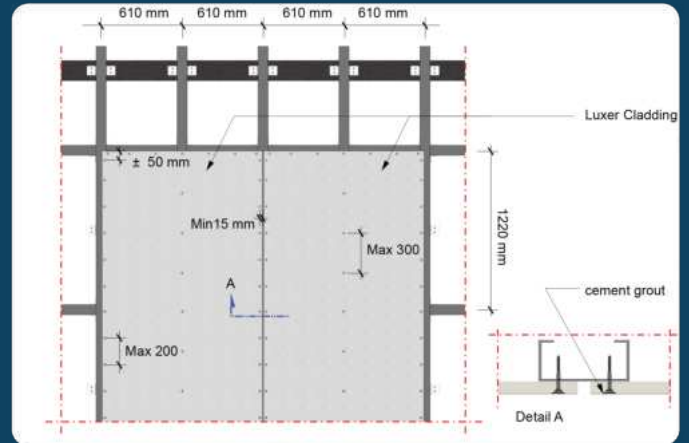

### SCREW POSITION

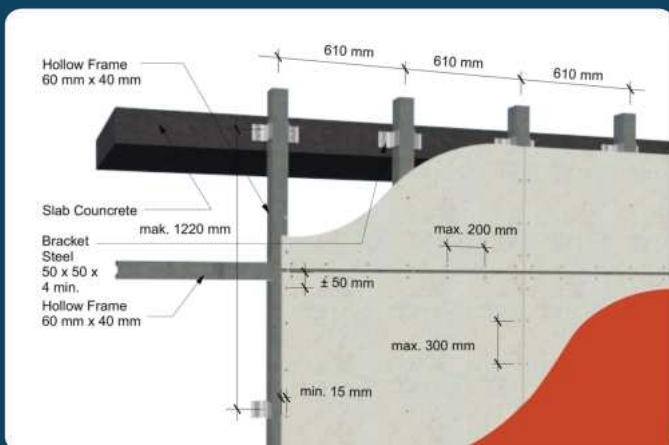

### DETAIL APPLICATION

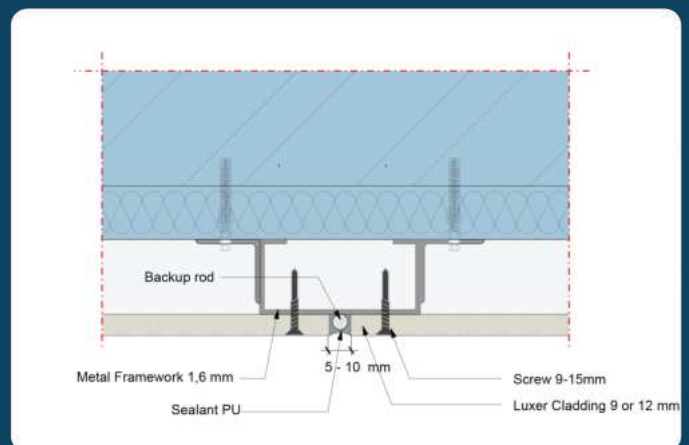



<b>Thickness (mm)</b>	9	10
<b>Length (mm)</b>	2440	2440
<b>Width (mm)</b>	1220	1220
<b>Weight (kg)</b>	43.5	48.5
<b>Application</b>	Wall Cover Decoration	

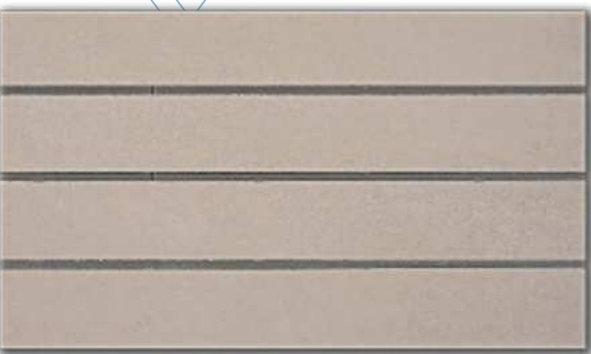
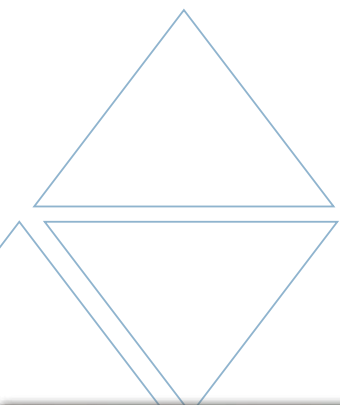

<b>Thickness (mm)</b>	9	10
<b>Length (mm)</b>	2440	2440
<b>Width (mm)</b>	1220	1220
<b>Weight (kg)</b>	43.5	48.5
<b>Application</b>	Wall Cover Decoration	

*\*It can be ordered with dimensions and designs according to the customer's preferences.*

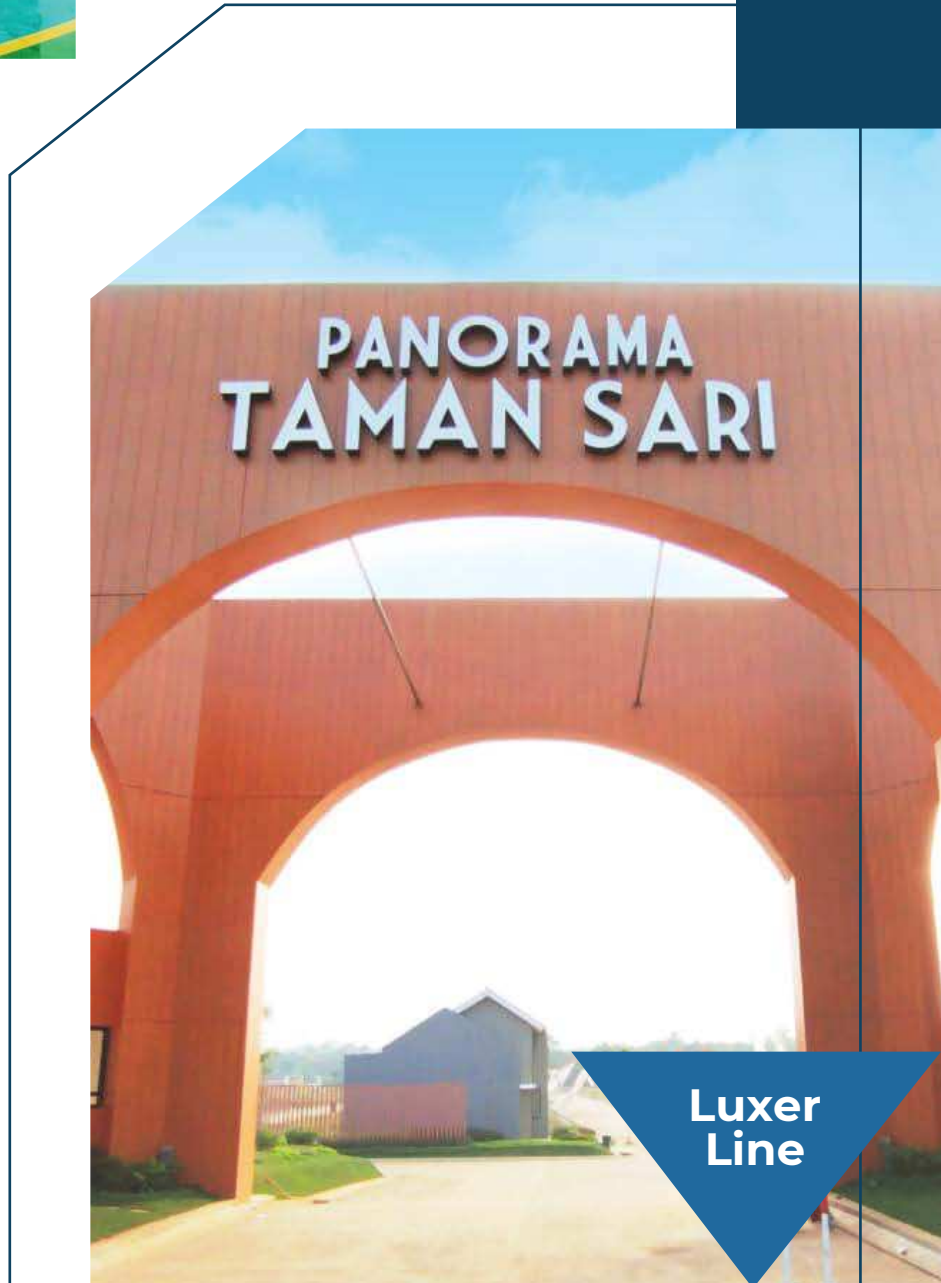



## PARTITION APPLICATION

### FRAMES

#### Metal Furring frames

75 x 45 mm thickness 1.6 mm

#### Hollow frames

60 x 40 mm thickness 1.6 mm

#### Angle bar

50 x 50 mm thickness 5 mm (min)

### Detail Application

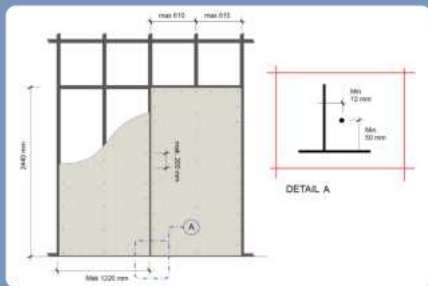

## CEILING APPLICATION

### Frames

#### Wood frames

40/60 mm 50/70 mm

#### Hollow frames

40/40 mm and 20/40 mm

minimum thickness 0.35 mm

### Detail Application

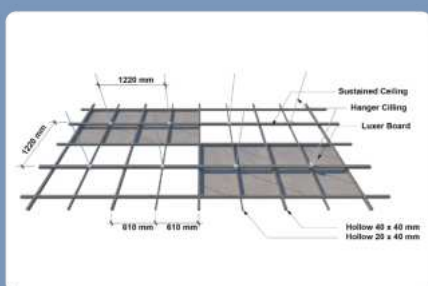

## LINE APPLICATION

### FRAMES

#### Hollow frames

60 x 40 mm thickness 1.2 mm

### Detail Position

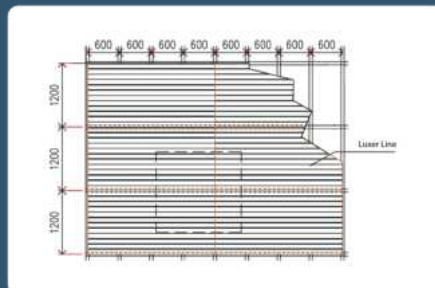

### Screw Position

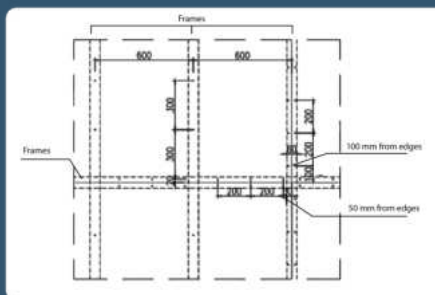

### Finishing

For Finishing on Luxer line application could apply water base or oil base paint.

## BRICK APPLICATION

### FRAMES

#### Hollow frames

60 x 40 mm thickness 1.2 mm

### Detail Position

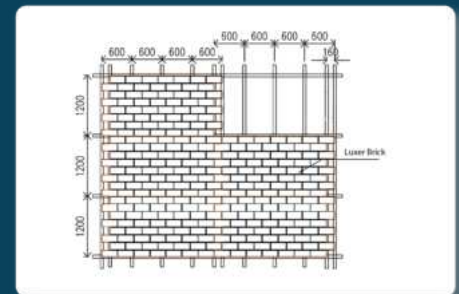

### Screw Position

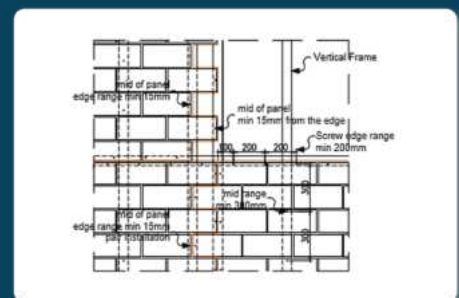

### Finishing

For Finishing on Luxer brick application could apply water base or oil base paint.



## PLANK & PLINT

In addition to being used for list plank applications, **Luxer Plank** products can also be used as interior applications protected from the weather, such as decorative ceilings, wall coverings, and plints. The list plank variants currently available are smooth plank, bevel plank, deco plank, and lastly, mahogany plank and rosewood plank, which are list plank products with surfaces resembling wood grain and fibers.

### Luxer Plank Smooth (Square Edge)

Thickness (mm)	8	8	8
Length (mm)	2440	2440	2440
Width (mm)	100	200	300
Weight (kg)	3.4	6.8	9.5
Application	Plint/Plank		

### Luxer Plank Mahogany

Thickness (mm)	8	8	8
Length (mm)	3000	3000	3000
Width (mm)	100	200	300
Weight (kg)	3.9/4	8	11
Application	Plank/Siding		

### Luxer Plank Beve

Thickness (mm)	9	9	9	9
Length (mm)	2440	2440	2440	2440
Width (mm)	75	100	200	300
Weight (kg)	2.8	3.8	7.5	11.3
Application	Plint/Plank			

### Luxer Plank Rosewood

Thickness (mm)	8	8
Length (mm)	3000	3000
Width (mm)	200	300
Weight (kg)	7.5	11.3
Application	Plank/Siding/Cover Column	

### Luxer Plank Deco

Thickness (mm)	9	9
Length (mm)	1200	1200
Width (mm)	200	300
Application	Decoration Plank	



## PLINT APPLICATION

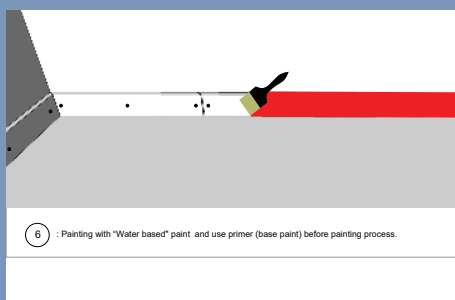
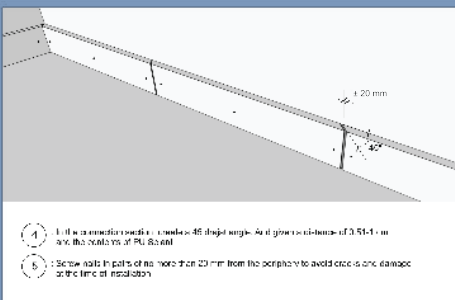
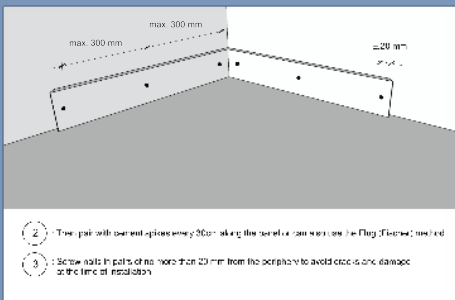
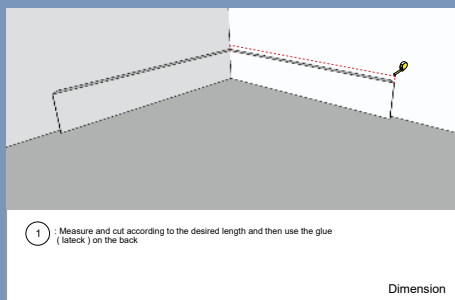

## SIDING APPLICATION

### FRAMES

**Wood frames**  
50 x 70 mm thickness 1.6 mm  
**Metal framework**  
thickness 1.2 mm

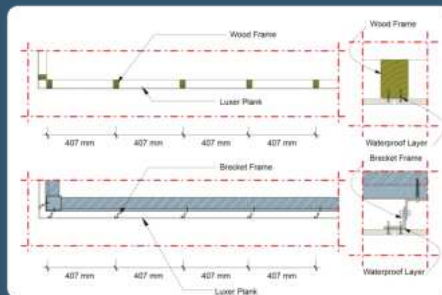

### Installation

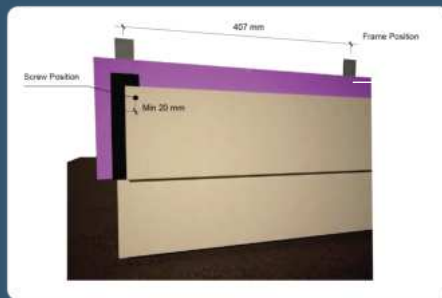

### Jointing

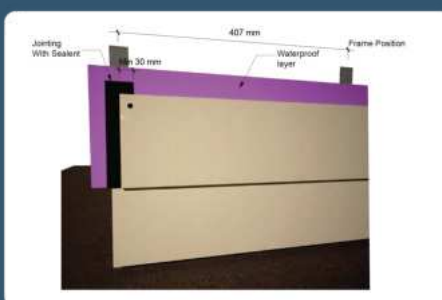

## CEILING GRID APPLICATION

### FRAMES

**Wood frames**  
50 x 70 mm thickness 1.6 mm  
**Hollow frames**  
40 x 40 mm thickness 0.6 mm

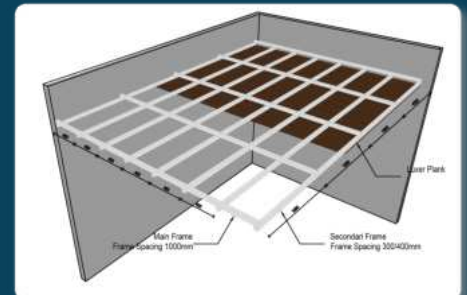

### Installation



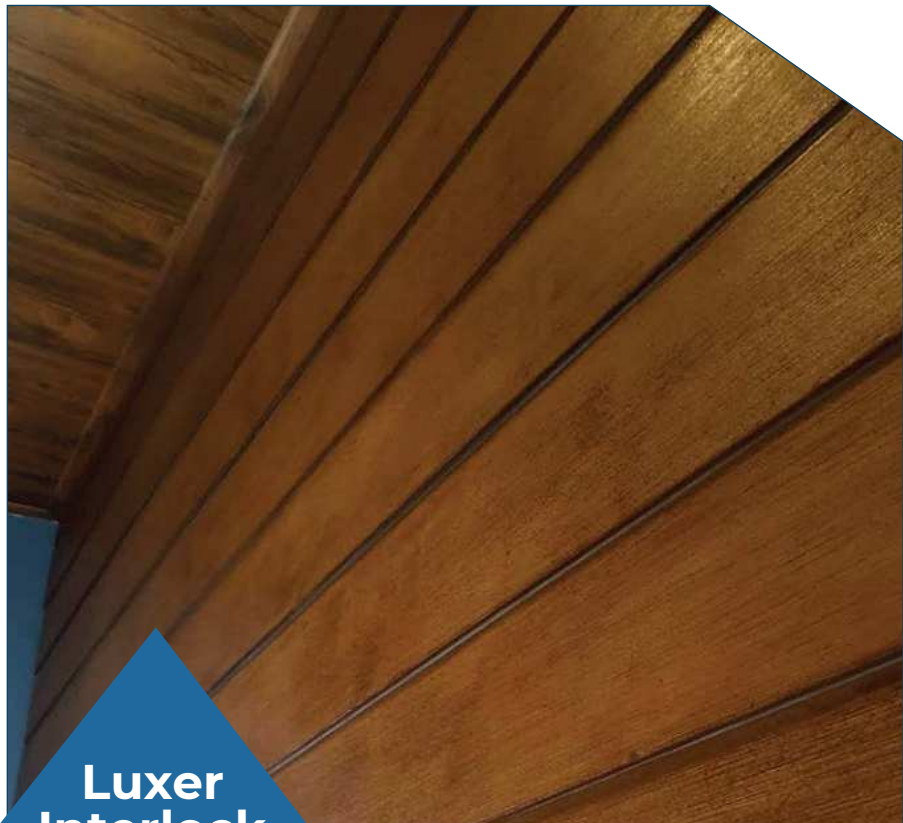

## Luxer Interlock

### INTERLOCK

*Luxer Interlock* is very suitable for application on facades or wall siding with profile line accents on each joint, making the shape and appearance of the walls look more beautiful and attractive.

Thickness (mm)	10	10	10
Length (mm)	3000	3000	3000
Width (mm)	150	200	300
Weight (kg)	7.6	10	15
Application	Façade/siding		



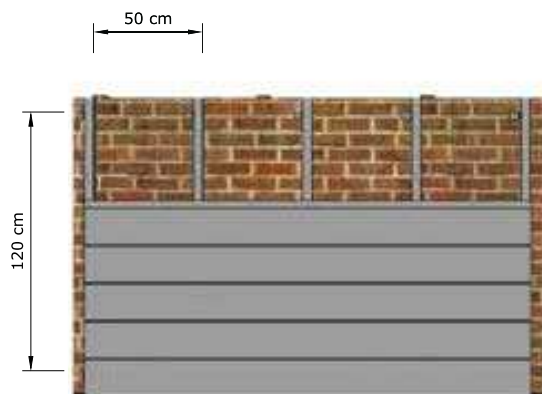

## INTERLOCK APPLICATION FRAMES

1. **Metal stud frames** 40/60 mm or 50/70 mm
2. **Hollow frames** combination 40/40 mm and 20/40 mm which has minimum thickness 0.35 mm

## INTERLOCK SCREW POSITION

1. Screw with a distance of 20mm from the edge of the top board "tongue"
2. Oversunk to a depth of 5mm before screwing with a larger diameter drill.

## INTERLOCK INSTALLATION

Install the next board right on the "tongue and groove".  
Give a 5 -10 mm gap 0.5-1 cm between each panel.



## Luxer Deck

Thickness (mm)	20	20
Length (mm)	2400	2400
Width (mm)	200	300
Weight (kg)	16.4	24.6
Application	Decking	

### DECK

The use of wood material as a floor or deck can now be replaced by **Luxer Deck** products, which are safe and easy to use in outdoor areas because Luxer Deck is made to withstand extreme weather.

**Luxer Deck**  
(Mahogany)

**Luxer Deck**  
(Smooth)

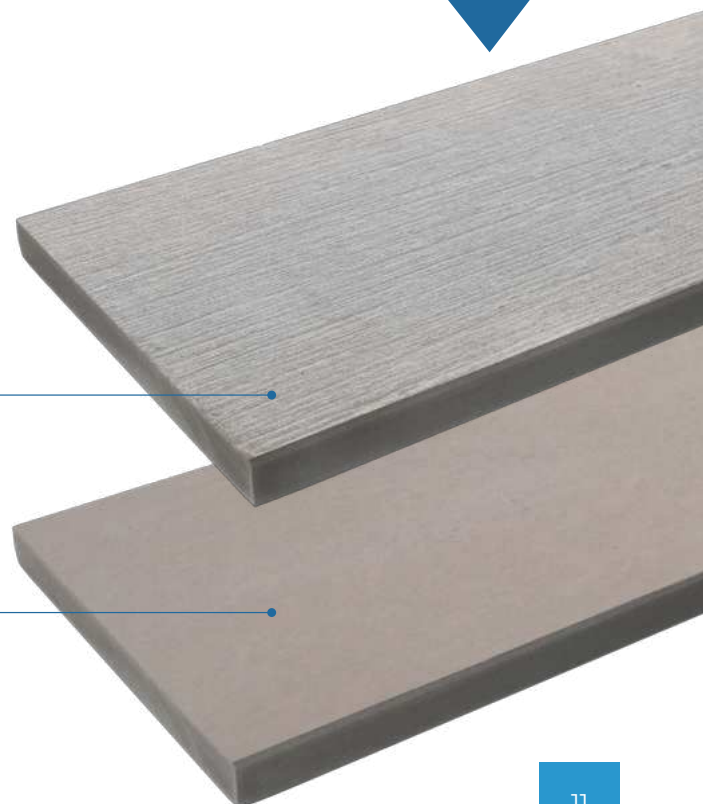

## DECK APPLICATION

### FRAMES

**Metal frame** CNP 100-125, Thickness 2-3 cm.  
The installation of support frame which is recommended is maximum 300 mm.

### DETAIL APPLICATION

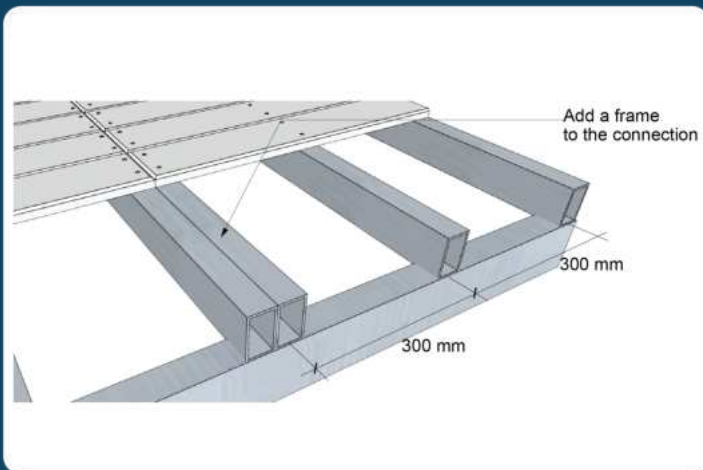

### SCREW POSITION

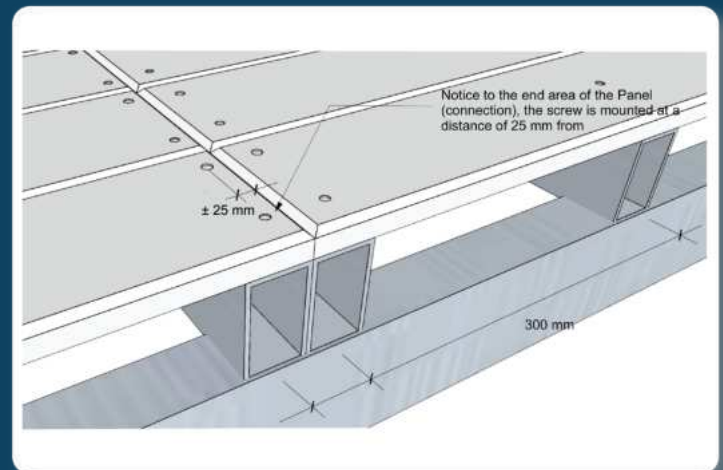

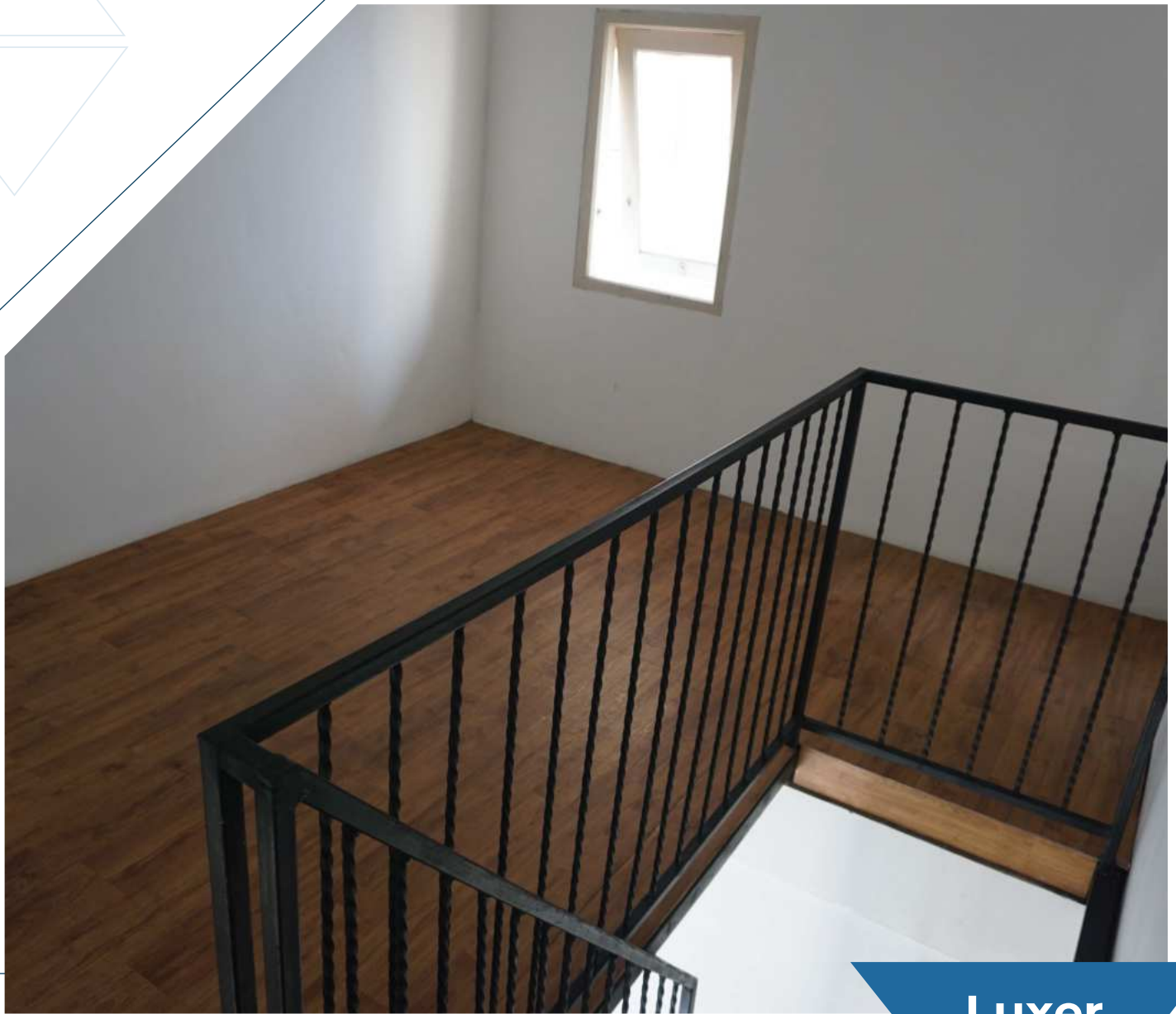

## Luxer Floor

Thickness (mm)	15	20
Length (mm)	2440	2440
Width (mm)	1220	1220
Weight (kg)	78.4	104.7
Application	Flooring	

### Floor

One of the cement board products with maximum thickness to withstand pressure and heavy loads according to its function as a floor.

### Luxer Floor



# FLOOR APPLICATION

## FRAMES

Light metal Framework , thickness min 2.3 mm.  
Hollow Steel and CNP, thickness min 2.3 mm.  
The installation of frame which is recommended is maximum 407 x 814 mm for 15 mm thickness and maximum 610 x 1220 mm for 20 mm thickness.

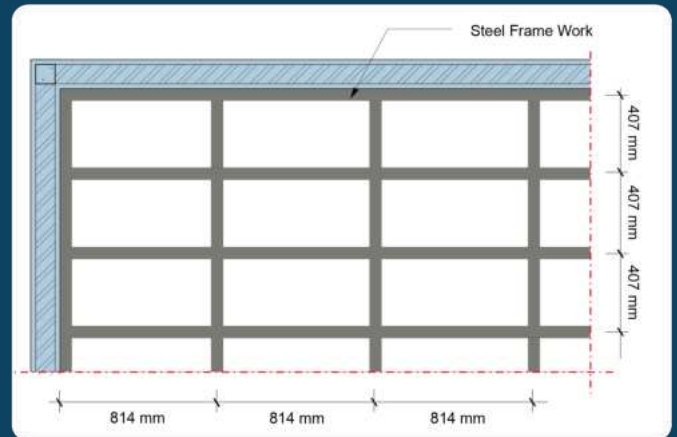

## SCREW POSITION

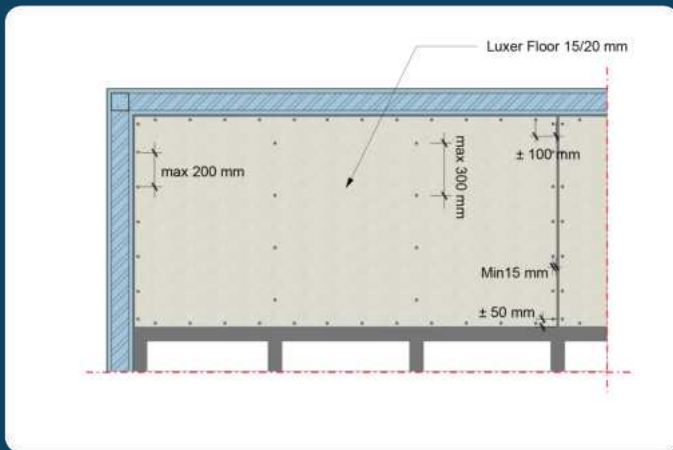

## DETAIL APPLICATION

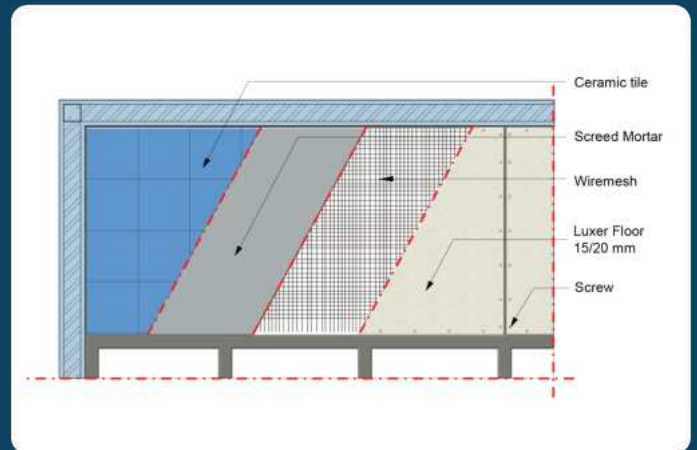



**Luxer  
Deco**

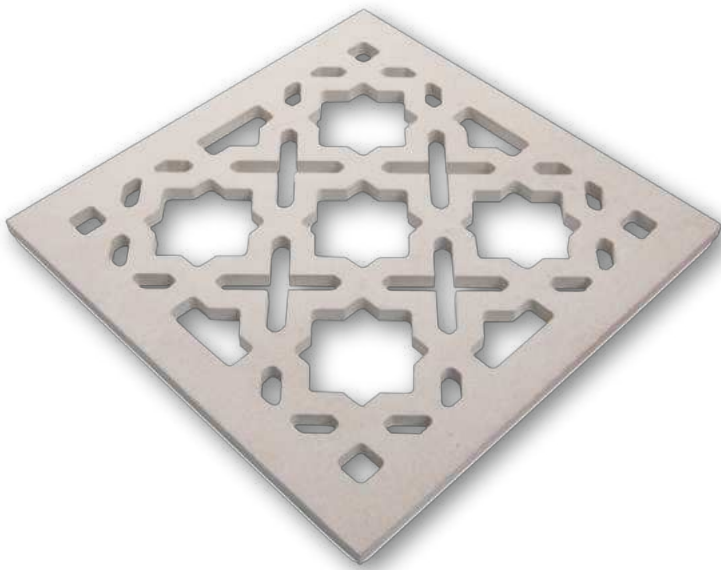

### **Deco**

***Luxer Deco** is a decorative product that can enhance the aesthetic beauty of a field or building, suitable for indoor and outdoor areas due to its varying product thickness. It can be ordered according to the size and thickness, even the design desired by the customer, which is one of the advantages of this product.*

<b>Thickness (mm)</b>	6-20
<b>Length (mm)</b>	2400 (MAX)
<b>Width (mm)</b>	1200 (MAX)
<b>Application</b>	Partition, Decoration

*Available with custom motifs, dimensions, and thicknesses, subject to applicable terms and conditions.*

# Project Reference

## Luxer Deco



# Accessories



## **Compound A + B**

**Compound A + B** is Luxer glue that serves to fill the gap between the Luxer board joints so that the connections between Luxer boards will not crack.



## **Luxer Tape**

**Luxer Tape** is a fiber tape used to strengthen connections. It is applied on top of the grout after applying Compound A+B.



## **Luxer Putty**

**Luxer Putty** is a pre-mixed mortar made from white cement, specially formulated for the final coat or finish on various types of cement-based walls.

## **Luxer Screw 3.5-4.5 mm**

These screws are designed for installing 3.5-4.5 mm Luxer Board.



## **Luxer Screw 5-8 mm**

These screws are designed for installing 5-8 mm Luxer Board.

## **Luxer Screw 9-15 mm**

These screws are designed for installing products with a thickness of 9 – 15 mm.

## **Luxer Screw > 15-20 mm**

These screws are designed for installing products with a thickness of > 15-20 mm.



## **Luxer Nails**

**Luxer Nails** are suitable for use on ceilings and partitions mounted on wood frames. They are designed with a larger and thinner head, making them easy to countersink.

# Technical Data

Physical Properties	
Tolerance on thickness	± 6%
Density	1550 ± 150 kg/m <sup>3</sup>
Dimensions tolerance	± 2 mm
Straightness of edges	≤ 0.2%
Squareness of edges Tolerance	≤ 0.4%
Modulus of Rupture	> 7 MPa (Wet)
	> 10 Mpa (Dry)
Moisture Content	≤ 7%
Water Absorption	≤ 35%
Water Permeability	Pass
PH Value	08-Jul
Length Change by Moisture Movement	≤ 0.04%
Asbestos Free	Pass
Sound Protection	33 dB (9mm thickness single wall)

Physical Properties	
PH Value	Pass
Length Change by Moisture Movement	Non-Combustible
Asbestos Free	Class 1

Durability Properties	
Freeze / Thaw Resistance	Pass
Warm Water Resistance	Pass
Heat / Rain Resistance	Pass
Soak / Dry Resistance	Pass
Termite Resistance JIS K 1571: 2010	Pass

Standard	Title
ISO 8336:2009	Fibre-cement flat sheets
AS/NZS 2908.2:2000	Cellulose-cement products - Flat sheets
MS 1296:2010	Fibre-cement flat sheets - Product specification and test methods
JIS A 1321:1994	Testing method for Incombustibility of internal finish material and procedure of buildings
JIS A 1304:2017	Method Of Fire Resistance Test For Elements Of Building Construction
AS 1530.1-1994	Methods for fire tests on building materials, components and structures Part 1: Combustibility test for materials
JIS K 1571:2010	Wood preservatives - Performance requirements and their test methods for determining effectiveness
ASTM E90-09	Standard Test Method for Laboratory Measurement of Airborne Sound Transmission Loss of Building Partitions and Elements
EPA 600/M4-82-020	Interim Method for the Determination of Asbestos in Bulk Insulation Samples
ASTM C1185-08	Standard Test Methods for Sampling and Testing Non-Asbestos Fiber-Cement Flat Sheet, Roofing and Siding Shingles, and Clapboards

## Product Warranty

**We Guarantee** that our products are sold in good condition without damage or faults caused by faulty production or its raw materials.

This product warranty does not cover damage caused by:

1. Transportation and/or its agents are responsible for delivering the goods to the customer, as it is beyond the company's control.
2. The quality of installation and the workers system are influenced by various factors that affect a proper and correct installation process.
3. The suitability of our product for a particular application that does not follow our recommendations.

# Product Application



## 1 Plafon Application

LUXER BOARD 4 mm

## 4 Cladding Application

LUXER BOARD 9 mm

## 7.1 Plank & Plint Application

- LUXER PLANK MAHOGANY
- LUXER PLANK SMOOTH
- LUXER PLANK ROSEWOOD
- LUXER PLANK BEVEL

## 2 Partition Application

LUXER BOARD 8 mm

## 5 Floor Application

LUXER FLOOR 20 mm

## 3 Roof Mat Application

LUXER BOARD 12 mm

## 6 Deck Application

- LUXER DECK MAHOGANY
- LUXER DECK SMOOTH

## 7.2 Siding Plank Application

LUXER INTERLOCK

## 8 Decorative Application

- 8.1 LUXER DECO
- 8.2 LUXER LINE
- 8.3 LUXER BRICK



**LUXER BOARD**

*FOR THE BUILDINGS OF TOMORROW*

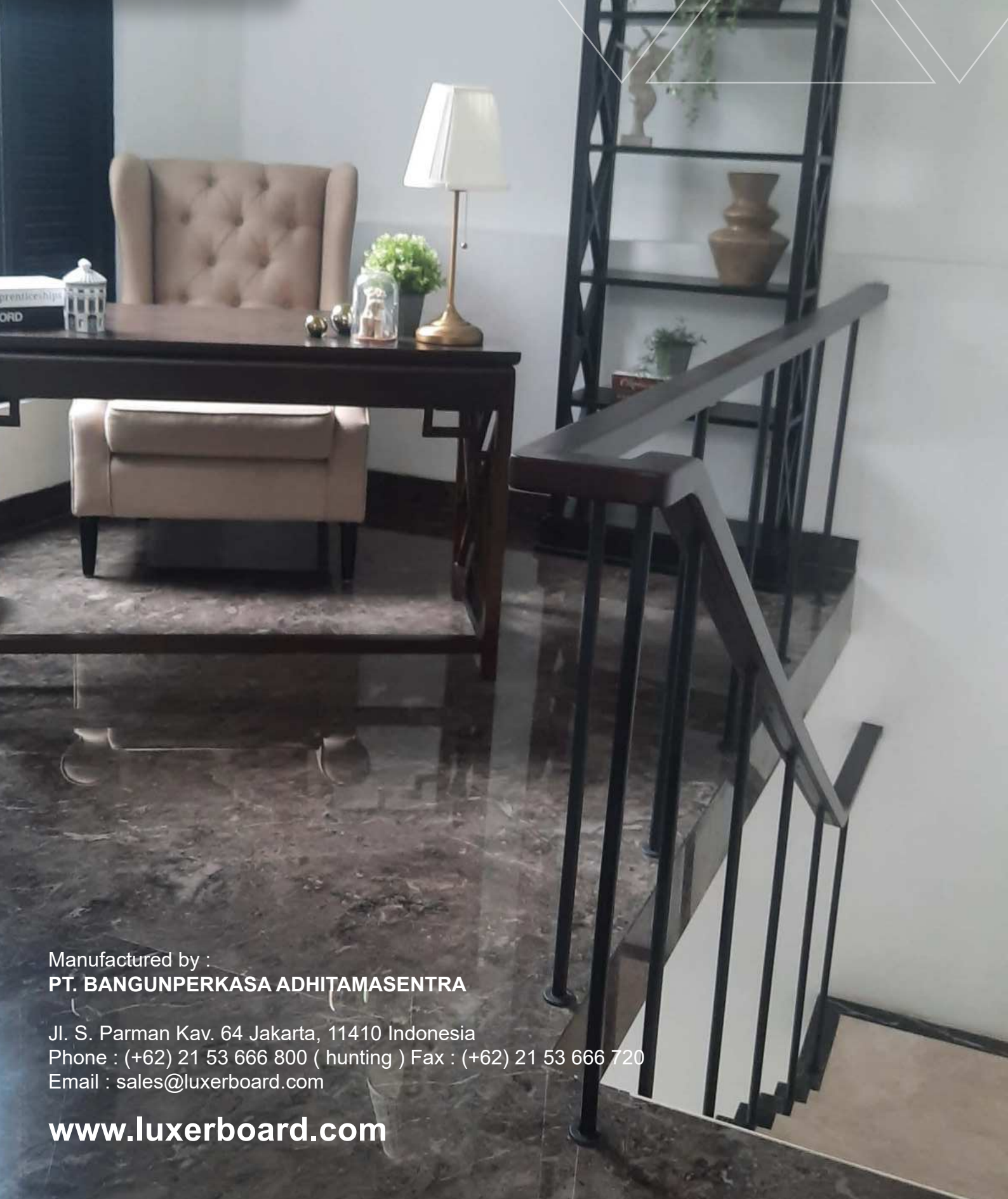

Manufactured by :  
**PT. BANGUNPERKASA ADHITAMASENTRA**

Jl. S. Parman Kav. 64 Jakarta, 11410 Indonesia  
Phone : (+62) 21 53 666 800 ( hunting ) Fax : (+62) 21 53 666 720  
Email : sales@luxerboard.com

**[www.luxerboard.com](http://www.luxerboard.com)**